

MASTERYS GP

Green Power 2.0 range

10 to 40 kVA/kW

3
LEVEL
TECHNOLOGY

96%
EFFICIENCY

kW
=
kVA



socomec
Innovative Power Solutions

OBJECTIVES

The aim of these specifications is to provide:

- the information required to choose the right uninterruptible power supply for a specific application.
- the information required to prepare the system and installation site.

The specifications are intended for:

- installation engineers.
- design engineers.
- engineering consultants.

INSTALLATION REQUIREMENTS AND PROTECTION

Connection to the mains power supply and to the load(s) must be made using cables of suitable size, in accordance with current standards. If not already present, an electrical control station which can isolate the network upstream of the UPS must be installed. This electrical control station must be equipped with a circuit breaker (or two, if there is a separate bypass line) of an appropriate rating for the power draw at full load.

If an external manual bypass is required, only the model supplied by the manufacturer must be installed.

We recommend fitting two metres of unanchored flexible cable between the UPS output terminals and the cable anchor (wall or cabinet). This makes it possible to move and service the UPS.

For detailed information, see the installation and operating manual.

1. ARCHITECTURE

1.1 RANGE

GREEN POWER 2.0 is a full range of high performing UPS designed to:

- ensure 24/7/365 availability and business continuity to datacentre infrastructures,
- to avoid data losses and downtime of company operations,
- to reduce the electrical infrastructure's total cost of ownership,
- to adopt a sustainable development approach.

GREEN POWER 2.0					
Rated power (kVA)	10	15	20	30	40
MASTERYS GP 3/1	•	•	•	-	-
MASTERYS GP 3/3	•	•	•	•	•

Matrix table for model and kVA power rating

Each family has been specifically designed to meet the demands of loads in specific application contexts, in order to optimise the features of the product and to facilitate its integration within the system.

2. FLEXIBILITY

2.1 POWER RATINGS FROM 10 TO 40 KVA/KW

The entire range is compatible with 3 cabinets, all with the same footprint. The UPS's power and autonomy thus translates into the height of the cabinet itself (800 mm, 1000 mm, 1400 mm).

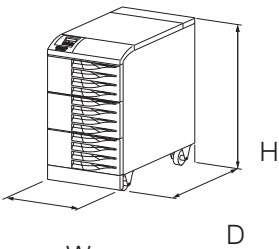
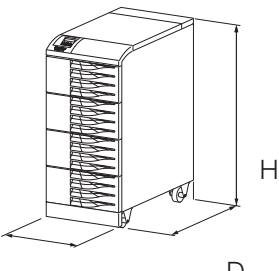
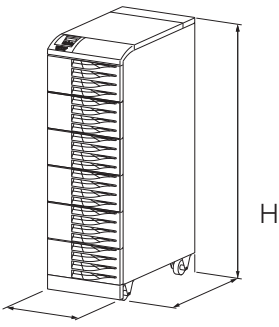
Dimensions			
Cabinet type	Width (W) [mm]	Depth (D) [mm]	Height (H) [mm]
 W S (short)	444	795	800
 W M (medium)	444	795	1000
 W T (tall)	444	795	1400

The equipment has been designed with a minimum direct and indirect footprint (the actual space occupied by the unit and the space required around it for maintenance, ventilation and access to the operating mechanisms and communication devices).

The careful design also provides easy access for maintenance and installation.

All of the control mechanisms and communication interfaces are located in the upper front part and can be accessed from the first panel with the red surround.

The air inlet is on the front, with outflow to the rear only; this means other equipment or external battery enclosures can be placed alongside the UPS unit.

2.2 FLEXIBLE BACK-UP TIME

Different extended back-up times are possible by using the standard UPS cabinet or the larger sized cabinet, both of which occupy minimum floor space.

For long back-up power periods, an additional cabinet should be used, optionally with a supplementary battery charger.

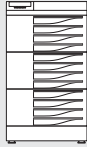
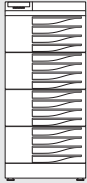
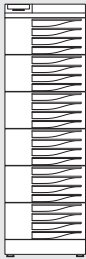
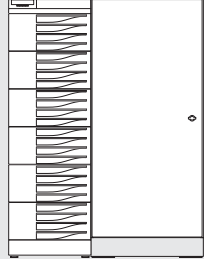
BACK-UP times in minutes (max @ 70% of load)				
GREEN POWER 2.0				
	S	M	T	T with supplementary battery cabinet ⁽¹⁾
MASTERYS GP 10 kVA/kW	16	35	80	•
MASTERYS GP 15 kVA/kW	9	22	49	•
MASTERYS GP 20 kVA/kW	6	16	35	•
MASTERYS GP 30 kVA/kW	-	9	22	•
MASTERYS GP 40 kVA/kW	-	6	21	•

(1) Supplementary battery cabinet 1000 x 800 x 1800mm (WxDxH)

Selection of the back-up time is flexible thanks to the wide range of DC bus voltages.

The batteries are organised internally into racks based on their relative sizes, so as to ensure a compact unit while still guaranteeing substantial back-up times.

The UPS system's internal batteries consist of distinct strings of battery packs connected in series; each individual pack is connected using polarised connectors to facilitate battery configuration and maintenance.

Each pack is sealed in an acid-proof container which is designed to prevent damage in the case of acid leakage.

To guarantee maximum back-up time availability and battery life, the GREEN POWER 2.0 MASTERYS GP series is equipped with EBS systems, depending on the model.

2.3 HORIZONTAL AND VERTICAL PARALLEL

GREEN POWER 2.0 MASTERYS GP offers 2 “configurations” of UPS in the same range.

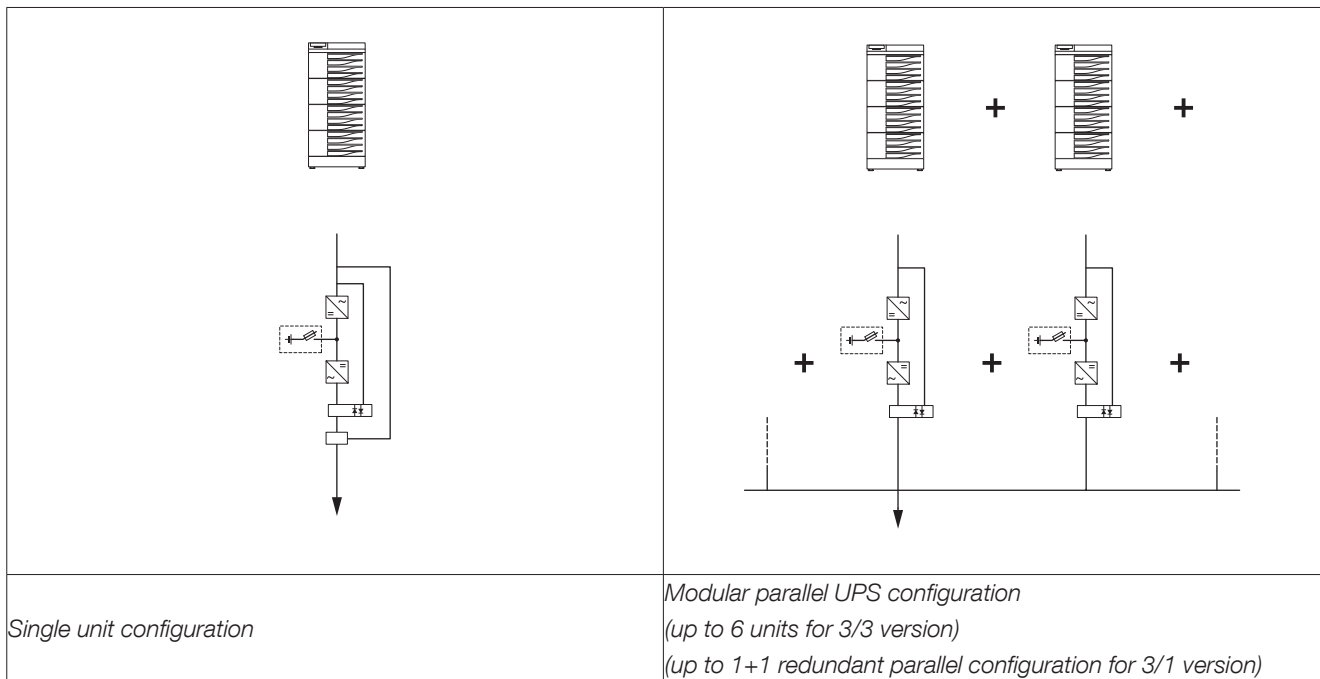

2.4 AVAILABILITY, REDUNDANCY AND EFFICIENCY

To increase the availability of the power supply, redundant parallel configurations are becoming increasingly common. Consequently, the overall efficiency of the UPS system risks being reduced due to the low load on each individual machine.

3. STANDARD AND OPTIONS

3.1 STANDARD ELECTRICAL FEATURES.

- Dual input mains.
- Internal maintenance bypass.
- Backfeed protection: detection circuit.
- EBS (Expert Battery System) for battery management.
- Battery temperature sensor.

3.2 ELECTRICAL OPTIONS.

- External maintenance bypass.
- External battery cabinet.
- Additional battery chargers.
- Galvanic isolation transformer.
- Parallel kit.
- ACS synchronization system.

3.3 STANDARD COMMUNICATION FEATURES.

- User-friendly multilingual interface with color graphic display.
- Commissioning wizard.
- 2 slots for communication options.
- MODBUS TCP.
- MODBUS RTU.
- Embedded LAN interface (web pages, email).

3.4 COMMUNICATION OPTIONS.

- Dry-contact interface.
- PROFIBUS.
- BACnet/IP interface
- NET VISION: professional WEB/SNMP interface for UPS monitoring and shutdown management of several operating systems.

3.5 REMOTE MONITORING SERVICE.

- LINK-UPS, remote monitoring service that connects your UPS to your Critical Power specialist 24/7.

4. SPECIFICATIONS

4.1 INSTALLATION PARAMETERS

Installation parameters									
Rated power (kVA)		10	15	20	10	15	20	30	40
Phase in/out		3/1			3/3				
Active power	kW	10	15	20	10	15	20	30	40
Rated/maximum rectifier input current (EN 62040-3)	A	16/22	24/30	31/39	16/22	24/30	31/39	47/56	62/73
Rated bypass input current	A	44	65	87	15	22	29	44	58
Inverter output current @ 230 V	A	44	65	87	15	22	29	44	58
Maximum air flow	m ³ /h	280						465	
Sound level	dB(A)	< 52						< 55	
Power dissipation in nominal conditions ⁽¹⁾	(W)	652	922	1274	646	927	1225	1709	2176
	kcal/h	561	793	1095	555	797	1053	1469	1871
	BTU/h	2226	3148	4350	2206	3165	4182	5835	7429
Power dissipation (max) in the worst conditions ⁽²⁾	mm	661	974	1382	686	1005	1333	1902	2474
	mm	568	837	1188	590	864	1146	1635	2128
	mm	2256	3324	4720	2340	3432	4550	6492	8448
Dimensions (with standard back-up time)	With	kg	444						
	Deep	kg	795						
	Height	mm	800/1000/1400					1000/1400	
Weight without batteries	kg	100	105	110	100	105	110	135	152
Weight with batteries	kg	190	195	240	190	195	240	315	415

1) Considering nominal input current (400 V, battery charged) and rated output active power (PF1).

2) Considering maximum input current (low input voltage, battery recharge) and rated output active power (PF1).

4.2 ELECTRICAL CHARACTERISTICS

Electrical characteristics - Rectifier ⁽¹⁾ Input									
Rated power (kVA)		10	15	20	10	15	20	30	40
Phase in/out		3/1			3/3				
Rated mains supply voltage		400 V 3ph + N							
Voltage tolerance		240 V to 480 V ⁽²⁾							
Rated frequency		50/60 Hz (selectable)							
Frequency tolerance		±10%							
Power factor (input at full load and rated voltage)		≥ 0.99							
Total harmonic distortion (THDi)		< 3%							
Max inrush current at start-up		< I _n (no overcurrent)							

(1) IGBT rectifier. (2) Conditions apply.

Electrical characteristics - Bypass									
Rated power (kVA)	10	15	20	10	15	20	30	40	
Phase in/out	3/1			3/3					
Bypass frequency variation speed	1 Hz/s (settable up to 3 Hz/s)								
Bypass rated voltage	Nominal output voltage $\pm 15\%$								
Bypass rated frequency (selectable)	50/60 Hz (selectable)								
Bypass frequency tolerance	$\pm 2\%$ (configurable from 1% to 8%)								

Electrical characteristics - Inverter										
Rated power (kVA)	10	15	20	10	15	20	30	40		
Phase in/out	3/1			3/3						
Rated output voltage (selectable)	220/230/240 V			380/400/415 V						
Output voltage tolerance	Static: $\pm 1\%$ Dynamic: VFI-SS-111 (EN62040-3) compliant									
Rated output frequency	50/60 Hz (selectable)									
Output frequency tolerance	$\pm 0.01\%$									
Load crest factor	$\geq 2.7:1$									
Voltage harmonic distortion	< 1% with linear load									
Overload tolerated by the inverter	10 min	kW	11.5	17.25	23.0	11.5	17.25	23.0	34.5	46.0
	1 min	kW	13.9	20.85	27.8	13.9	20.85	27.8	41.7	55.6

Electrical characteristics - Efficiency									
Rated power (kVA)	10	15	20	10	15	20	30	40	
Phase in/out	3/1			3/3					
Double conversion efficiency (normal mode - @ full load)	up to 96%								
Efficiency in EcoMode	98%								

Electrical characteristics - Environment									
Rated power (kVA)	10	15	20	10	15	20	30	40	
Phase in/out	3/1			3/3					
Storage temperatures	-5 to +45 °C (23 to 113 °F) (15 to 25 °C for better battery life)								
Working temperature	0 to +40 ⁽¹⁾ °C (32 to 104 °F) (15 to 25 °C for better battery life)								
Maximum relative humidity (non-condensing)	95%								
Maximum altitude without derating	1000 m (3300 ft)								
Degree of protection	IP20 (other IP as option)								
Portability	ASTM D999-08, ASTM D-880, AFNOR NF H 00-042								
Colour	RAL 7012								

(1) Conditions apply.

4.3 RECOMMENDED PROTECTIONS

RECOMMENDED PROTECTION DEVICES - Rectifier ⁽¹⁾								
Rated power (kVA)	10	15	20	10	15	20	30	40
Phase in/out	3/1			3/3				
D curve circuit breaker (A)	32		40	32		40	63	80
gG fuse (A)	32		40	32		40	63	80

RECOMMENDED PROTECTION DEVICES - General bypass ⁽¹⁾								
Rated power (kVA)	10	15	20	10	15	20	30	40
Phase in/out	3/1			3/3				
Maximum I ² t supported by the bypass (A ² s)	80000			8000		15000		
I _{cc} max (A)	4000			1200		1700		
D curve circuit breaker (A)	100		125	32		40	63	80
gG fuse (A)	100		125	32		40	63	80

RECOMMENDED PROTECTION DEVICES - Input residual current circuit breaker ⁽²⁾								
Rated power (kVA)	10	15	20	10	15	20	30	40
Phase in/out	3/1			3/3				
Input residual current circuit breaker	> 0.5 A Selective							

RECOMMENDED PROTECTION DEVICES - Output ⁽³⁾									
Model	10	15	20	10	15	20	30	40	
Phase in/out	3/1			3/3					
Short-circuit inverter current (A) (when AUX MAINS is not present)	0 to 40 ms	113	165	216	38	56	74	117	156
	40 to 100 ms	95	140	183	32	48	62	95	126
C curve circuit breaker ⁽³⁾ (A)	≤ 10	≤ 16	≤ 20	≤ 4		≤ 6	≤ 10	≤ 13	
B curve circuit breaker ⁽³⁾ (A)	≤ 20	≤ 32	≤ 40	≤ 8		≤ 12	≤ 20	≤ 25	
High-speed fuse ⁽³⁾ (A)	≤ 12	≤ 18	≤ 24	≤ 6		≤ 10	≤ 12	≤ 16	

CABLES - Maximum cable section								
Model	10	15	20	10	15	20	30	40
Phase in/out	3/1			3/3				
Rectifier terminals	MKDSP 25/4 - 25 mm ² (flexible cable), 35 mm ² (rigid cable)							
Bypass terminals	MKDSP 25/4 - 25 mm ² (flexible cable), 35 mm ² (rigid cable)							
Battery terminals	MKDSP 25/4 - 25 mm ² (flexible cable), 35 mm ² (rigid cable)							
Output terminals	MKDSP 25/4 - 25 mm ² (flexible cable), 35 mm ² (rigid cable)							

(1) Rectifier protection should only be considered in the event of separate inputs. The bypass protection is given by recommendation. When the bypass and rectifier inputs are combined (common input), the general input protection rating must be the highest of both (bypass or rectifier).

(2) Must be selective with residual current circuit breakers downstream of the UPS connected to the UPS output. If the bypass network is separate from the rectifier circuit, or in the event of parallel UPS, use a single residual current circuit breaker upstream of the UPS.

(3) Selectivity of distribution after the UPS with inverter short-circuit current (short-circuit with AUX MAINS not present). The rating of the protection can be increased by "n" times downstream a parallel UPS system, with "n" equal to the number of parallel modules.

5. REFERENCE STANDARDS AND DIRECTIVES

5.1 OVERVIEW

The construction of the equipment and choice of materials and components comply with all laws, decrees, directives and standards currently in force.

In particular, the equipment is fully compliant with all European Directives concerning CE marking.

2006/95/EC

Council Directive 2006/95/EC, dated 16 February 2007, on the reconciliation of legislation within Member States regarding electrical material for use within specific voltage ranges.

2004/108/EC

On the approximation of the laws of the Member States relating to electromagnetic compatibility

5.2 STANDARDS

5.2.1 ELECTROMAGNETIC COMPATIBILITY

“Electromagnetic Compatibility Provisions (EMC)”

EN 62040-2 Electromagnetic compatibility (C2 category)

5.2.2 SAFETY

“General and safety requirements for UPS used in operator access areas”

EN 60950-1 General and safety requirements for equipment used in operator access areas

EN 62040-1 General and safety requirements for UPS used in restricted access locations (certified by TÜV SÜD)

EN 50272-2 Safety requirements for secondary batteries and battery installations

EN 60529 Degrees of protection provided by enclosures

5.2.3 TYPE AND PERFORMANCES

“Performance requirements and methods of test”

EN 62040-3 Uninterruptible power systems (UPS). Methods of specifying the performance and test requirements

5.3 SYSTEM AND INSTALLATION GUIDELINES

Once installed in a system, the UPS will not alter the neutral conditions; this is because the neutral input terminal “N” is connected directly to output terminal “N1” inside the equipment. If the neutral condition of the system downstream of the UPS needs to be modified, it will be necessary to use the isolation transformer option.

The regulations refer to the unit (UPS) to which the manufacturer must comply with. The UPS engineer adhere’s to current legislation for the specific electrical system (e.g. EN 60364).

